



(19) **United States**

(12) **Patent Application Publication**
Muruyama et al.

(10) **Pub. No.: US 2004/0061670 A1**

(43) **Pub. Date: Apr. 1, 2004**

(54) **ORGANIC EL PANEL DRIVE CIRCUIT**

(57) **ABSTRACT**

(76) Inventors: **Junichi Muruyama**, Nagaoka, Niigata (JP); **Akira Suzuki**, Nagaoka, Niigata (JP)

Correspondence Address:
McDermott Will & Emery
600 13th Street N W
Washington, DC 20005-3096 (US)

(21) Appl. No.: **10/250,787**

(22) PCT Filed: **Aug. 22, 2002**

(86) PCT No.: **PCT/JP02/08484**

(30) **Foreign Application Priority Data**

Nov. 16, 2001 (JP) 2001-350872

Publication Classification

(51) **Int. Cl.⁷ G09G 3/30**

(52) **U.S. Cl. 345/76**

Drive switches **3b1** to **3bn** selectively apply a constant current to any one of anode electrode lines **1A**. Constant current sources **3a1** to **3an** supply the constant current to anode electrode lines **1A**, respectively, via drive switches **3b1** to **3bn**. Scanning switches **2a1** to **2am** selectively set any one of cathode electrode lines **1B** to a ground potential and apply a reverse bias voltage to the other cathode electrode lines **1B**. First temperature compensation means **5a** for detecting an ambient temperature of organic EL devices **E11** to **Enm**, and generates a first temperature compensation drive voltage **VA** obtained by changing a power supply voltage according to an output from the temperature detection means **5a** and supplies the first temperature compensation drive voltage **VA** to the constant current sources **3a1** to **3an**. Second temperature compensation means **6** applies a temperature-compensated second temperature compensation drive voltage **VB**, which is generated based upon the first temperature compensation drive voltage **VA** outputted from the first temperature compensation means **5**, to the cathode electrode lines **1B** as the reverse bias voltage via the scanning switches **2a1** to **2am**.

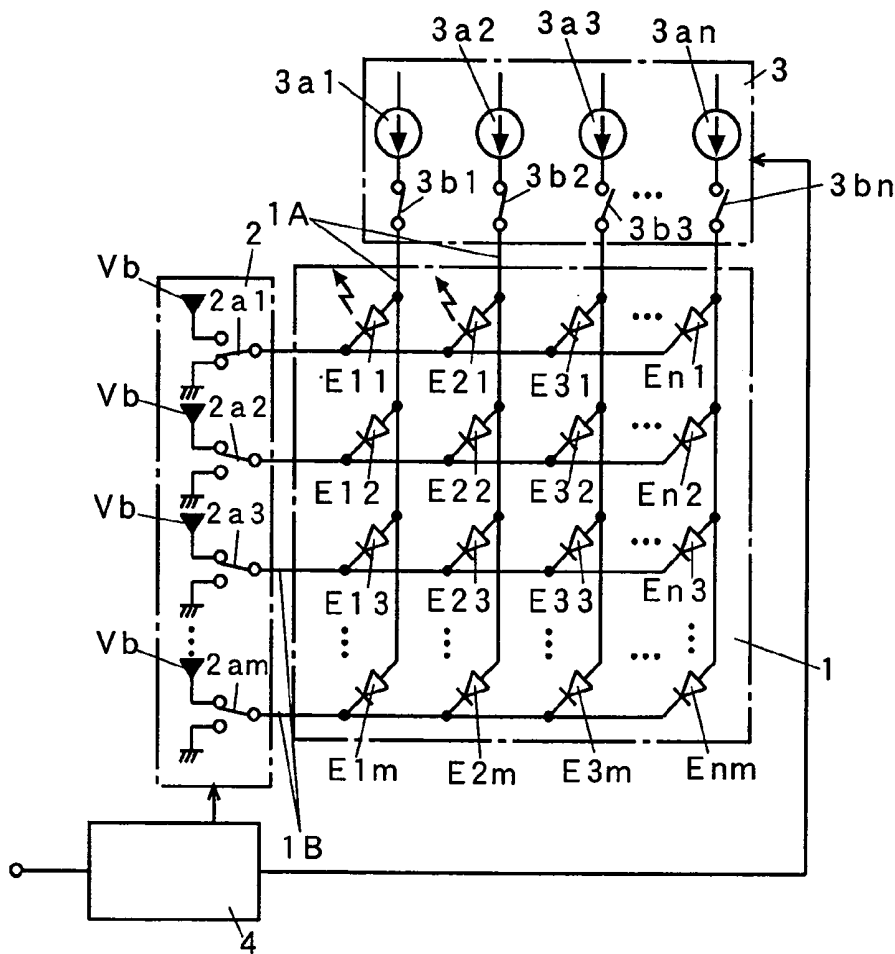

4 : CONTROL UNIT

FIG. 1

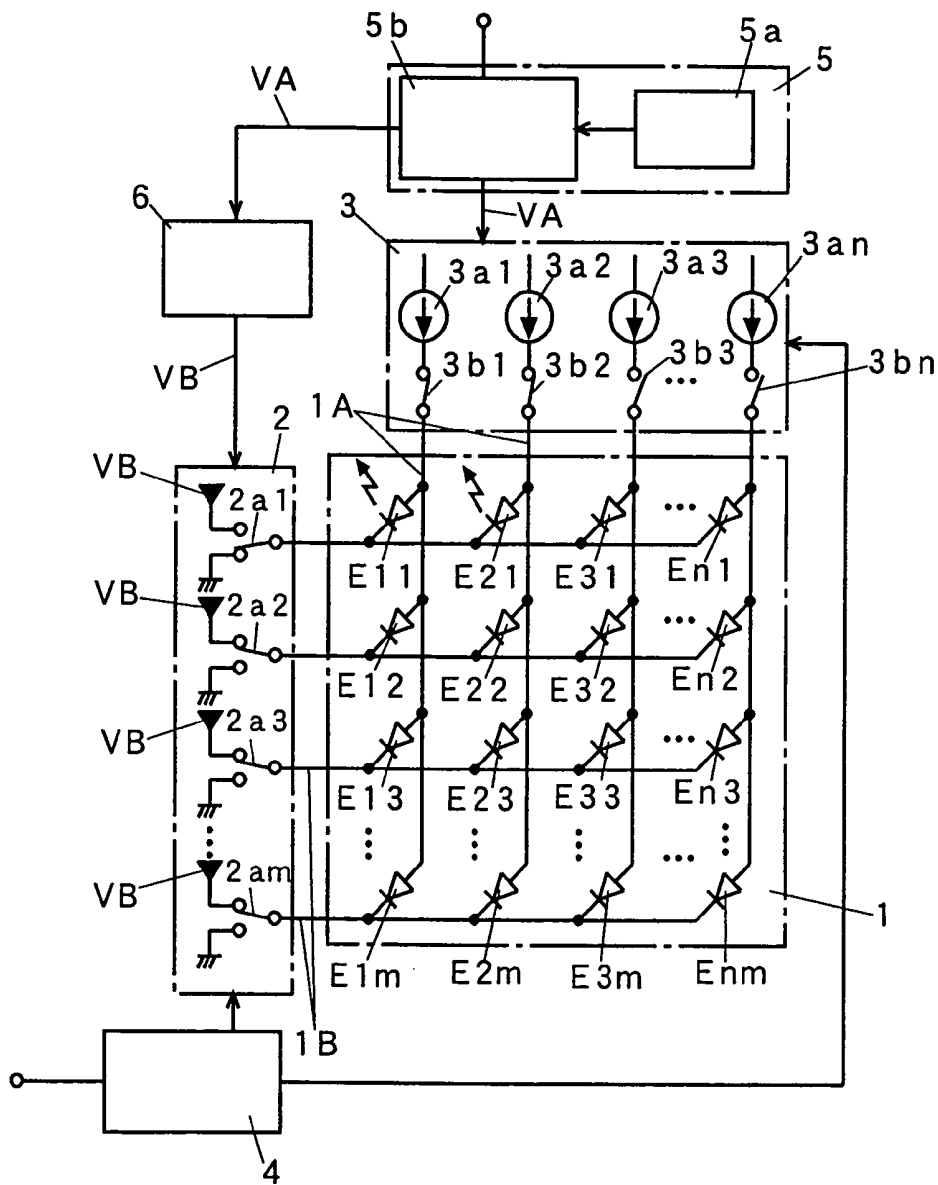

- 4 : CONTROL UNIT
- 5 : FIRST TEMPERATURE COMPENSATION MEANS
- 5 a : TEMPERATURE DETECTION MEANS
- 5 b : POWER SUPPLY CIRCUIT
- 6 : SECOND TEMPERATURE COMPENSATION MEANS

FIG. 2

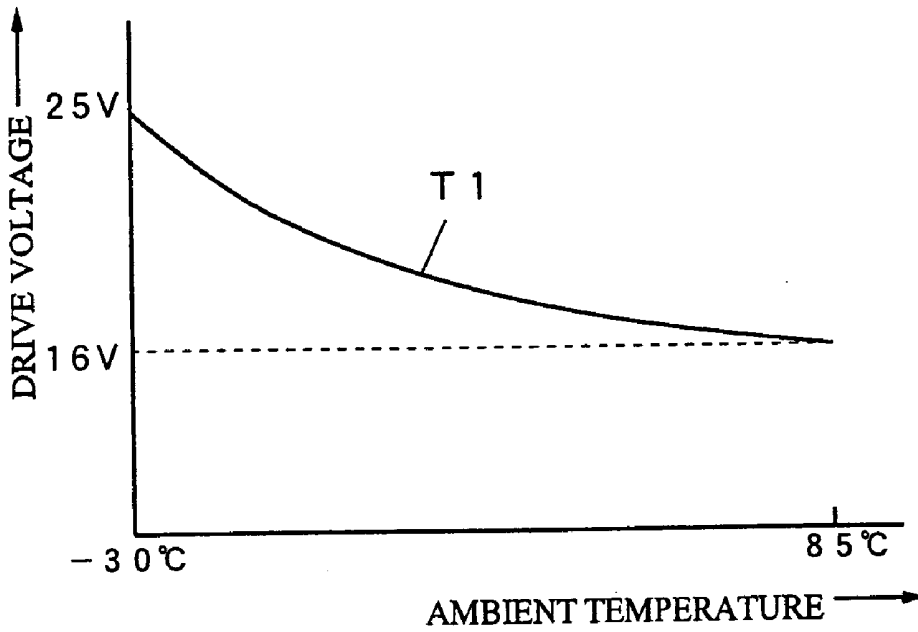

FIG. 3

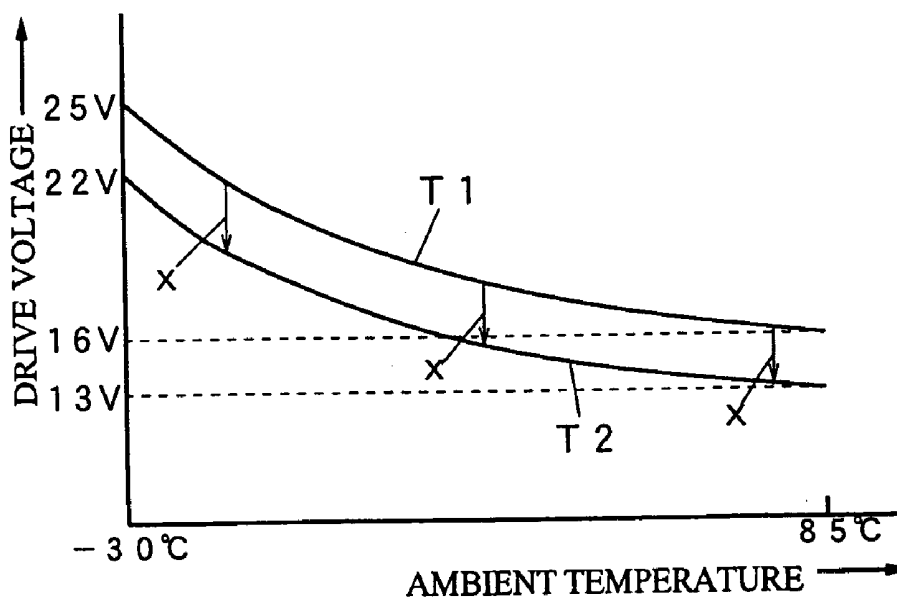

FIG. 4

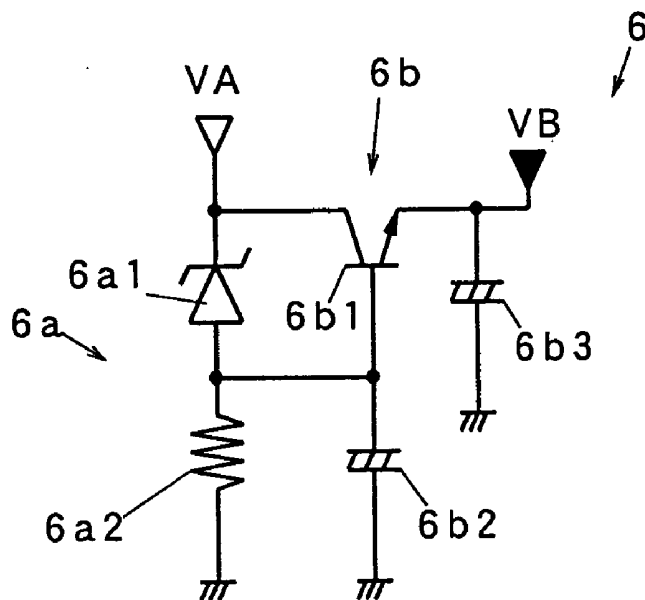

FIG. 5

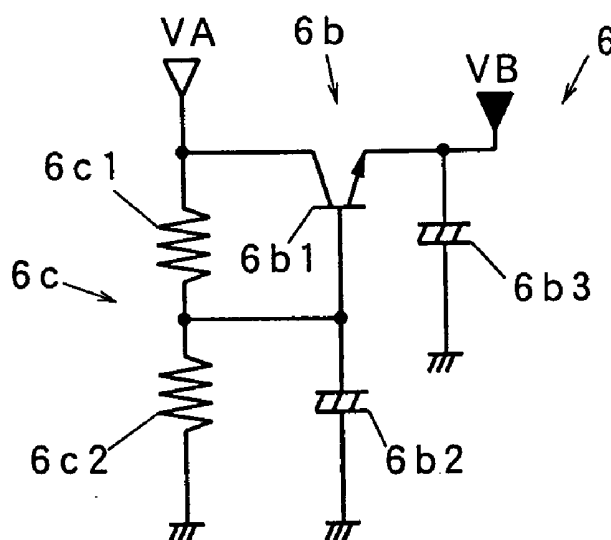
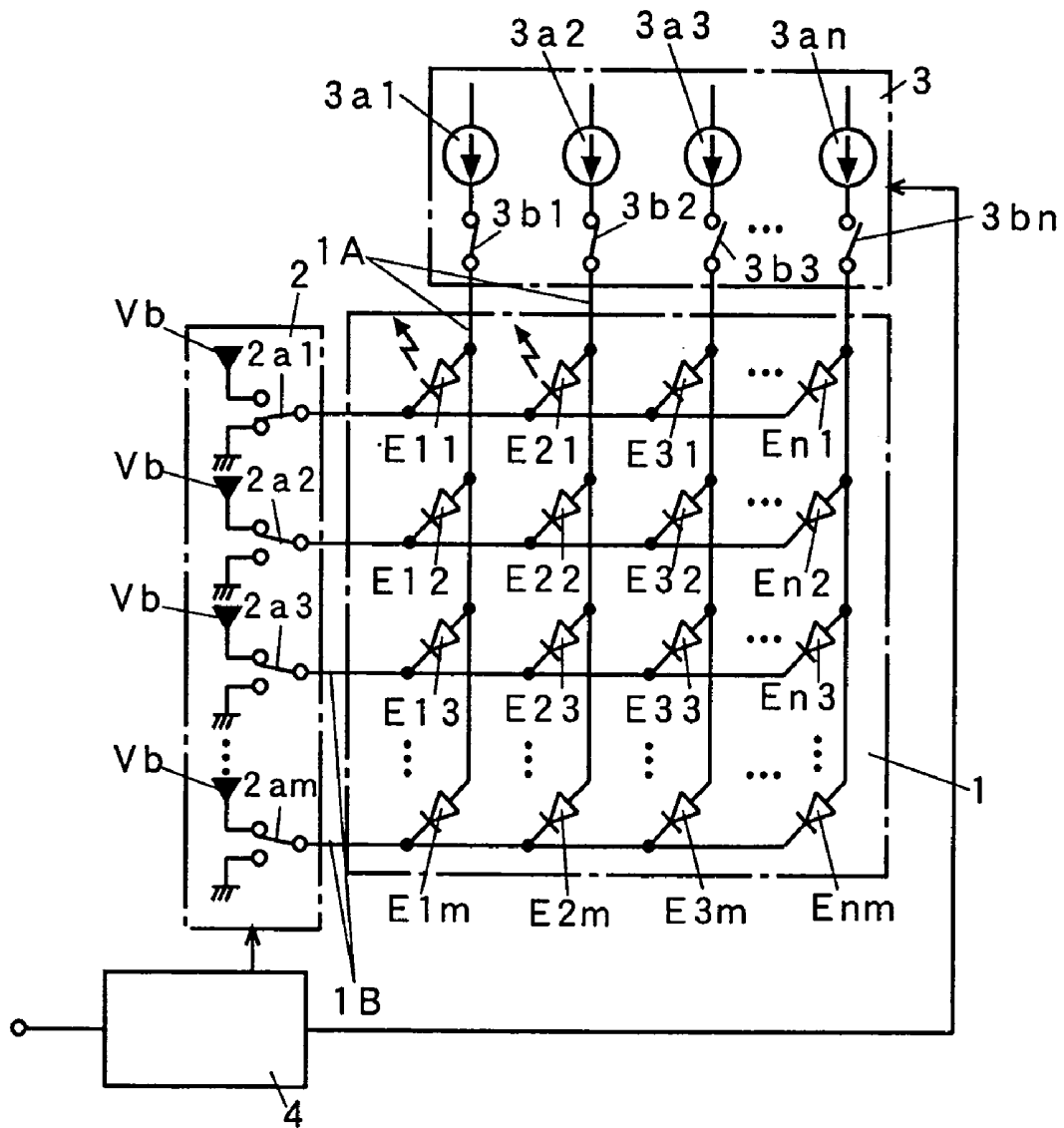

FIG. 6



4 : CONTROL UNIT

ORGANIC EL PANEL DRIVE CIRCUIT

TECHNICAL FIELD

[0001] The present invention relates to a drive circuit for an organic EL panel provided with organic EL devices of a dot matrix type.

BACKGROUND ART

[0002] As an organic EL panel provided with organic EL devices serving as constant current drive devices, there is, for example, one described in JP-A-2001-142432. This is an organic EL panel of a dot matrix type in which plural anode electrode lines using a conductive transparent film such as an ITO (Indium Tin Oxide) are formed in parallel with each other on a translucent insulating support substrate such as a glass substrate, an organic layer (organic EL layer) is formed on the back of these anode electrode lines, plural parallel cathode electrode lines using a metal evaporated film such as aluminum is formed on the back of this organic layer so as to be perpendicular to the anode electrode lines, and the organic layer is held by these anode electrode lines and cathode electrode lines. The organic EL panel has been attracting attentions as a display, which is capable of realizing low power consumption, high display quality, and reduced thickness, substituting a liquid crystal display.

[0003] As a drive circuit for such an organic EL panel, there is one shown in FIG. 6. Such a drive circuit includes an organic EL panel 1, a cathode side drive circuit 2, an anode side drive circuit 3, and a control unit 4.

[0004] The organic EL panel 1 is formed by disposing organic EL devices E11 to Enm bearing pixels in a lattice shape. In a structure of these organic EL devices E11 to Enm, an organic layer including at least a light-emitting layer is held in crossing parts of plural anode electrode lines 1A, which are provided so as to be laid along a vertical direction, and plural cathode electrode lines 1B, which are provided so as to be perpendicular to the anode electrode lines 1A. If represented as an equivalent circuit, the organic EL devices E11 to Enm are formed with one ends thereof connected to the anode electrode lines 1A (anode side of a diode component) and the other ends connected to the cathode electrode lines 1B (cathode side of a diode component).

[0005] The cathode side drive circuit 2 is provided with plural scanning switches 2a1 to 2am corresponding to the respective cathode electrode lines 1B and selects a reverse bias voltage Vb, which becomes a power supply voltage on the cathode side in the respective organic EL devices E11 to Enm, or a ground potential (0V) with the scanning switches 2a1 to 2am based upon a control signal of the control unit 4. That is, the organic EL devices E11 to Enm come into a non-light emitting state when the reverse bias voltage Vb is selected by the scanning switches 2a1 to 2am and come into a light emitting state when the ground potential is selected by the scanning switches 2a1 to 2am.

[0006] The anode side drive circuit 3 is provided with constant current sources 3a1 to 3an, which supply a constant current (drive current) to the anode electrode lines 1A, respectively, in association with them, and is constituted such that the constant current from these constant current sources 3a1 to 3an is supplied to the respective anode

electrode lines 1A via the respective drive switches 3b1 to 3bn. Changeover of the respective drive switches 3b1 to 3bn is determined based upon a control signal from the control unit 4.

[0007] The control unit 4 includes a microcomputer and, for example, when travel information of a vehicle is inputted from various sensors, in an attempt to perform predetermined arithmetic operation processing and to display various kinds of information such as a vehicle speed, an engine speed, and residual fuel on the organic EL panel 1, outputs the travel information to the cathode side drive circuit 2 and the anode side drive circuit 3, respectively, as a control signal, and selectively turns ON/OFF the scanning switches 2a1 to 2am and the drive switches 3b1 to 3bn corresponding to the cathode electrode and anode electrode lines 1B, 1A necessary for causing the organic EL devices E11 to Enm to emit light, thereby causing the organic EL panel 1 to display predetermined information. The drive circuit of the organic EL panel comprises the above portions.

[0008] In such a drive circuit of the organic EL panel 1, gradation control is performed which is based upon pulse width modulation (PWM) of the cathode and anode scanning lines 1B, 1A corresponding to the scanning switches 2a1 to 2am and the drive switches 3b1 to 3bn in the cathode side drive circuit 2 and the anode side drive circuit 3, and the organic EL devices E11 to Enm bearing pixels are driven by the reverse bias voltage (output voltage) Vb, which is a non-selected/selected voltage in the cathode side drive circuit 2, and an output current from the constant current sources 3a1 to 3an in the anode side drive circuit 3.

[0009] However, in the organic EL devices E11 to Enm which have temperature dependency making it possible to emit light with a smaller drive voltage as temperature rises, in order to eliminate reactive power consumed in the anode side drive circuit 3, the organic EL devices E11 to Enm have to be controlled such that a drive voltage is reduced as an ambient temperature rises and that the drive voltage is increased as the ambient temperature falls.

[0010] In addition, there is a problem as described below. If the reverse bias voltage Vb in the cathode side drive circuit 2 suitable for the ambient temperature is not given to the organic EL devices E11 to Enm, in gradation control for one scanning line (light intensity control for one period based upon PWM) in the organic EL device E11 to Enm emitting light by the reverse bias voltage (output voltage) Vb and the output voltage of the constant current sources 3a1 to 3an, the reverse bias voltage Vb on the cathode side becomes larger than a light emission start voltage (drive voltage of an organic EL device suitable for an ambient temperature) in the organic EL devices E11 to Enm. When the reverse bias voltage Vb is selected by the scanning switches 2a1 to 2am in the cathode side drive circuit 2 in this state, in an organic EL device coupled to the selected cathode electrode line 1B, a charging current is generated by a capacitor component included in the organic EL device. Thus, the reverse bias voltage Vb reaches a light emission voltage concurrently with sharp rising, and light exceeding a predetermined luminance is emitted, although this occurs only in an instance. Note that, although influence of the light emission luminance exceeding the predetermined luminance in the organic EL devices E11 to Enm is relatively inconspicuous if a current application time from the constant

current sources **3a1** to **3an** by the gradation control is long, the influence becomes more conspicuous as the current application time is shortened by the gradation control.

[0011] The present invention has been devised in view of the above-mentioned problem and provides a drive circuit for an organic EL panel capable of controlling generation of reactive power even in the case in which an ambient temperature changes and, at the same time, keeping a light emission luminance of an organic EL device bearing pixels constant.

DISCLOSURE OF THE INVENTION

[0012] The present invention is a drive circuit for an organic EL panel which is provided with first and second electrode lines, at least one of which is translucent, in a plural form, respectively, and in which an organic layer including at least a light-emitting layer is held between the respective electrode lines to constitute an organic EL device of a dot matrix shape, the drive circuit for an organic EL panel comprising: anode scanning means for selectively applying a constant current to any one of the first electrode lines; a constant current source which supplies the constant current to the first electrode lines, respectively, via the anode scanning means; cathode scanning means for selectively setting any one of the second electrode lines to a ground potential and applying a reverse bias voltage to the other second electrode lines; first temperature compensation means which is provided with temperature detection means for detecting an ambient temperature of the organic EL devices, and generates a first temperature compensation drive voltage obtained by changing a power supply voltage according to an output from the temperature detection means and supplies the first temperature compensation drive voltage to the constant current source; and second temperature compensation means which applies a temperature-compensated second temperature compensation drive voltage, which is generated based upon the first temperature compensation drive voltage outputted from the first temperature compensation means, to the second electrode lines as the reverse bias voltage via the cathode scanning means.

[0013] The second temperature compensation means generates the second temperature compensation drive voltage which has a predetermined offset amount with respect to the first temperature compensation drive voltage obtained by the first temperature compensation means and determines the offset amount with offset means which is formed by connecting a Zener diode and a resistor in series.

[0014] In addition, the second temperature compensation means applies the second temperature compensation voltage of a predetermined ratio with respect to the first temperature compensation drive voltage obtained by the first temperature compensation means to the second electrode lines via the cathode scanning means and generates the second temperature compensation drive voltage divided at a predetermined ratio with respect to the first temperature compensation drive voltage by voltage dividing means formed by connecting at least two registers in series.

[0015] Therefore, in the cathode side in the organic EL panel, since it becomes possible to give a second temperature compensation drive voltage, which becomes a proper drive voltage according to an ambient temperature, to the cathode electrode means, it becomes possible to suppress

generation of a light emission luminance exceeding a predetermined luminance as in the past. Thus, it becomes possible to suppress a change in luminance with respect to temperature change of organic EL devices bearing pixels, and it is possible to obtain satisfactory display on an organic EL panel and marketability can be improved.

BRIEF DESCRIPTION OF THE DRAWINGS

[0016] FIG. 1 is a block diagram showing a drive circuit for an organic EL panel of this embodiment,

[0017] FIG. 2 is a graph showing a temperature voltage characteristic of the organic EL panel of this embodiment,

[0018] FIG. 3 is a graph showing a temperature voltage characteristic following an offset amount of the organic EL panel of this embodiment,

[0019] FIG. 4 is a diagram showing second temperature compensation means in the drive circuit of this embodiment, and

[0020] FIG. 5 is a diagram showing another second temperature compensation means of this embodiment,

[0021] FIG. 6 is a block diagram showing a conventional drive circuit for an organic EL panel.

BEST MODE FOR CARRYING OUT THE INVENTION

[0022] An embodiment of the present invention will be hereinafter described based upon the accompanying drawings. Parts identical with or equivalent to those in the conventional example are denoted by identical reference numerals, and detailed descriptions of the parts will be omitted.

[0023] As shown in FIG. 1, a drive circuit in this embodiment comprises an organic EL panel **1**, a cathode side drive circuit **2**, an anode side drive circuit **3**, a control unit **4**, first temperature compensation means **5**, and second temperature compensation means **6**.

[0024] In the organic EL panel **1**, plural anode electrode lines (first electrode lines) **1A** and cathode electrode lines (second electrode lines) **1B** are disposed in which the anode electrode lines **1A** and the cathode electrode lines **1B** are perpendicular (crossing) with each other, and an organic layer including at least a light-emitting layer is held in these crossing parts to constitute organic light-emitting devices **E11** to **Enm**.

[0025] The cathode side drive circuit **2** selects a reverse bias voltage **VB**, which becomes a power supply voltage on a cathode side and is generated by the second temperature compensation means **6** described in detail later, or a ground potential with scanning switches **2a1** to **2am**.

[0026] The anode side drive circuit **3** is provided with constant current sources **3a1** to **3an** for each anode electrode line **1** and selectively applies an output current (constant current) from the constant current sources **3a1** to **3an** to the anode electrode lines **1A** via respective drive switches **3b1** to **3bn**.

[0027] The control unit **4** outputs a control signal to the cathode side drive circuit **2** and the anode side drive circuit **3**, respectively, in an attempt to drive organic EL devices

E11 to Enm in the organic EL panel 1, selectively turns ON/OFF the scanning switches 2a1 to 2am and the drive switches 3b1 to 3bn of the cathode electrode and anode electrode lines 1B, 1A, and causes the organic EL devices E11 to Enm bearing pixels to emit light to thereby display various kinds of information.

[0028] The first temperature compensation means 5 is provided with temperature detection means 5a which consists of a thermistor for detecting a change in ambient temperature as a change in resistance value, and a power supply circuit 5b which supplies a first temperature compensation voltage (first temperature compensation voltage) VA obtained by fluctuating a drive voltage (power supply voltage) in the first temperature compensation means 5 in accordance with an output in the temperature detection means 5a, that is, the change in ambient temperature to the constant current sources 3a1 to 3an, thereby supplying a constant current to the respective anode electrode lines 1A via the drive switches 3b1 to 3bn. Note that the power supply circuit 5b is a well-known circuit which comprises, for example, a booster circuit for raising an original power supply voltage to obtain a drive voltage, a driver IC, and the like.

[0029] FIG. 2 shows a first temperature compensation characteristic T1 indicating a relation between the first temperature compensation drive voltage VA, which is supplied from the anode side drive circuit 3 to the organic EL panel 1, and an ambient temperature (−30 degrees Celsius to 85 degrees Celsius). The first temperature compensation means 5 generates the first temperature compensation drive voltage VA following the first temperature compensation characteristic T1 based upon an output from the temperature detection means 5a. Note that it is assumed that the first temperature compensation drive voltage VA changes, for example, within a range of 25V to 16V according to an ambient temperature.

[0030] The second temperature compensation means 6 sets the first temperature compensation voltage VA generated by the first temperature compensation means 5 as a power supply voltage and generates a second temperature compensation voltage VB to be a reverse bias voltage in the cathode side drive circuit 2. That is, as shown in FIG. 3, the second temperature compensation means 6 sets the second temperature compensation voltage VB, which is based upon a second temperature voltage characteristic T2 having a predetermined offset amount x (first temperature compensation drive voltage V—offset voltage) with respect to the first temperature voltage characteristic T1, as a reverse bias voltage (power supply voltage) VB of the cathode side drive circuit 2. Note that, in the case in which the offset amount x is assumed to be, for example, 3V with respect to the first temperature compensation drive voltage VA, when the first temperature compensation drive voltage VA in the first temperature voltage characteristic T1 changes in a range of 25V to 16V, the second temperature compensation drive voltage VB in the second temperature voltage characteristic T2 changes in a range of 22V to 13V.

[0031] The second temperature compensation means 6 has a circuit structure as shown in FIG. 4 in order to obtain the second temperature voltage characteristic T2 having the fixed offset amount x with respect to the first temperature voltage characteristic T1. That is, the second temperature

compensation means 6 consists of a power supply output section 6b having offset means 6a in order to obtain the second temperature voltage characteristic T2. The offset means 6a consists of a Zener diode 6a1 and a resistor 6a2 connected in series. The power supply output section 6b comprises an npn transistor 6b1 and electrolytic capacitors 6b2, 6b3. Therefore, one end side of the offset means 6a (cathode side of the Zener diode 6a1) is connected to the drive power supply (first temperature compensation drive voltage) VA and the other end side (resistor 6a2 side) thereof is connected to the ground potential to give a voltage divided by the Zener diode 6a1, and the resistor 6a2 is given as a base voltage of the npn transistor 6b1 in the power supply output section 6b, whereby the second temperature drive voltage VB having the predetermined offset amount x with respect to the first temperature compensation drive voltage VA is obtained. Note that the offset amount x depends upon the Zener diode 6a1 and the resistor 6a2, and fluctuation occurs in the offset amount x by an amount of loss of reactive power due to heat generation of the Zener diode 6a1, the resistor 6a2, components of the power supply output section 6b, or the like. However, if the fluctuation is in a level not affecting a light emission luminance of the organic EL panel 1, the offset amount x is assumed to be a predetermined offset amount x.

[0032] Such a drive circuit for the organic EL panel 1 comprises: drive switches 3b1 to 3bn for selectively applying a constant current to any one of the anode electrode lines 1A; the constant current sources 3a1 to 3an which supply the constant current to the anode electrode lines 1A, respectively, via the drive switches 3b1 to 3bn; the scanning switches 2a1 to 2am for selectively setting any one of the cathode electrode lines 1B to a ground potential and applying the reverse bias voltage VB to the other cathode electrode lines 1B; the first temperature compensation means 5 which is provided with the temperature detection means 5a for detecting an ambient temperature of the organic EL devices E11 to Enm, and generates the first temperature compensation drive voltage VA obtained by changing a power supply voltage according to an output from the temperature detection means 5a and supplies the first temperature compensation drive voltage VA to the constant current sources 3a1 to 3an; and the second temperature compensation means 6 which applies the temperature-compensated second temperature compensation drive voltage VB, which is generated based upon the first temperature compensation drive voltage VA outputted from the first temperature compensation means 5, to the cathode electrode lines 1B via the scanning switches 2a1 to 2am.

[0033] That is, the second temperature compensation means 6 generates the second temperature compensation drive voltage VB, which has the predetermined offset amount x with respect to the first temperature compensation drive voltage VA obtained by the first temperature compensation means 5, with the power supply output section 6b having the offset means 6a which is formed by connecting the Zener diode 6a1 and the resistor 6a2 in series. Therefore, in the cathode side of the organic EL panel 1, since it becomes possible to give the reverse bias voltage (second temperature compensation drive voltage) VB, which becomes a proper drive voltage according to an ambient temperature, to the cathode electrode lines 1B, it becomes possible to suppress generation of a light emission luminance exceeding a predetermined luminance as in the past.

Thus, it becomes possible to suppress a change in luminance with respect to temperature change of organic EL devices bearing pixels, and it is possible to obtain satisfactory display on the organic EL panel 1 and marketability can be improved.

[0034] In addition, in the anode side, again, since it becomes possible to supply the first temperature compensation drive voltage VA, which becomes an optimal drive voltage according to an ambient temperature, to the constant current sources 3a1 to 3an in the anode side drive circuit 3, it becomes possible to reduce generation of reactive power of drive devices in the constant current sources 3a1 to 3an following a change in ambient temperature. Thus, since it becomes possible to suppress harmful influence to the anode side drive circuit 3 by heat generation, durability can be improved.

[0035] FIG. 5 shows another embodiment mode in the second temperature compensation means 6. The embodiment mode is different from the above-mentioned embodiment mode in that the second temperature compensation drive voltage (reverse bias voltage) VB is obtained by voltage dividing means 6c instead of the offset means 6a.

[0036] In the second temperature compensation means 6, the respective resistors (at least two resistors) 6c1, 6c2 are connected in series and, at the same time, the first temperature compensation drive voltage VA is divided by the resistor 6c1 and the resistor 6c2, and this voltage obtained by dividing the first temperature compensation drive voltage VA is given as a base voltage of the transistor 6b1, whereby the second temperature compensation drive voltage VB divided at a predetermined ratio with respect to the first temperature compensation drive voltage VA is obtained.

[0037] In such an embodiment mode, the second temperature compensation means 6 generates the second temperature compensation drive voltage VB divided at a predetermined ratio with respect to the first temperature compensation drive voltage VA obtained by the first temperature compensation means 5 (a second temperature voltage characteristic T2' fallen at a predetermined ratio with respect to the first temperature voltage characteristic T1. In the cathode side of the organic EL panel 1, since it becomes possible to give the reverse bias voltage (second temperature compensation drive voltage) VB, which becomes a proper drive voltage corresponding to an ambient temperature, to the cathode electrode lines 1B, it becomes possible to minimize a change in luminance with respect to temperature change of the organic EL device bearing pixels as in the above-mentioned embodiment mode.

[0038] Note that the second temperature compensation drive voltage VB obtained by dividing the first temperature compensation drive voltage VA depends upon the two resistors 6c1, 6c2, and fluctuation occurs in the second temperature compensation drive voltage VB by an amount of loss of reactive power due to heat generation of the respective resistor 6c1, 6c2, components of the power supply output section 6b, or the like. However, if the fluctuation is in a level not affecting a light emission luminance of the organic EL panel 1, it is assumed that the second temperature compensation drive voltage VB is divided at a predetermined ratio.

INDUSTRIAL APPLICABILITY

[0039] As described above, the drive circuit for an organic EL panel in accordance with the present invention is a drive circuit which is particularly effective in a display panel provided with an organic EL device of a dot matrix type.

1. A drive circuit for an organic EL panel which is provided with first and second electrode lines, at least one of which is translucent, in a plural form, respectively, and in which an organic layer including at least a light-emitting layer is held between the respective electrode lines to constitute an organic EL device of a dot matrix shape, characterized by comprising: anode scanning means for selectively applying a constant current to any one of the first electrode lines; a constant current source which supplies the constant current to the first electrode lines, respectively, via the anode scanning means; cathode scanning means for selectively setting any one of the second electrode lines to a ground potential and applying a reverse bias voltage to the other second electrode lines; first temperature compensation means which is provided with temperature detection means for detecting an ambient temperature of the organic EL devices, and generates a first temperature compensation drive voltage obtained by changing a power supply voltage according to an output from the temperature detection means and supplies the first temperature compensation drive voltage to the constant current source; and second temperature compensation means which applies a temperature-compensated second temperature compensation drive voltage, which is generated based upon the first temperature compensation drive voltage outputted from the first temperature compensation means, to the second electrode lines as the reverse bias voltage via the cathode scanning means.

2. A drive circuit for an organic EL panel according to claim 1, characterized in that the second temperature compensation means generates the second temperature compensation drive voltage which has a predetermined offset amount with respect to the first temperature compensation drive voltage obtained by the first temperature compensation means.

3. A drive circuit for an organic EL panel according to claim 2, characterized in that the second temperature compensation means determines the offset amount with offset means which is formed by connecting a Zener diode and a resistor in series.

4. A drive circuit for an organic EL panel according to claim 1, characterized in that the second temperature compensation means applies the second temperature compensation voltage of a predetermined ratio with respect to the first temperature compensation drive voltage obtained by the first temperature compensation means to the second electrode lines via the cathode scanning means.

5. A drive circuit for an organic EL panel according to claim 4, characterized in that the second temperature compensation means is provided with voltage dividing means formed by connected at least two registers in series and generates the second temperature compensation drive voltage divided at a predetermined ratio with respect to the first temperature compensation drive voltage by the voltage dividing means.

* * * * *

专利名称(译)	有机EL面板驱动电路		
公开(公告)号	US20040061670A1	公开(公告)日	2004-04-01
申请号	US10/250787	申请日	2002-08-22
[标]申请(专利权)人(译)	MURUYAMA JUNICHI 铃木AKIRA		
申请(专利权)人(译)	MURUYAMA JUNICHI 铃木AKIRA		
当前申请(专利权)人(译)	日本精机股份有限公司		
[标]发明人	MURUYAMA JUNICHI SUZUKI AKIRA		
发明人	MURUYAMA, JUNICHI SUZUKI, AKIRA		
IPC分类号	H01L51/50 G09G3/20 G09G3/30 G09G3/32		
CPC分类号	G09G3/3216 G09G2310/0256 G09G2330/028 G09G2320/041 G09G2320/043 G09G2320/029		
优先权	2001350872 2001-11-16 JP		
其他公开文献	US7012584		
外部链接	Espacenet USPTO		

摘要(译)

驱动开关3b1至3bn选择性地向任何一个阳极电极线1A施加恒定电流。恒流源3a1至3an分别通过驱动开关3b1至3bn向阳极线1A提供恒定电流。扫描开关2a1至2am选择性地将阴极电极线1B中的任何一个设定为地电位，并将反向偏压施加到其他阴极电极线1B。第一温度补偿装置5设置有温度检测装置5a，用于检测有机EL装置E11至Enm的环境温度，并产生通过根据温度检测的输出改变电源电压而获得的第一温度补偿驱动电压VA。装置5a将第一温度补偿驱动电压VA提供给恒流源3a1至3an。第二温度补偿装置6将基于从第一温度补偿装置5输出的第一温度补偿驱动电压VA产生的温度补偿的第二温度补偿驱动电压VB施加到阴极电极线1B作为反向偏置电压通路。扫描开关2a1至2am。

